

Fault Recognition in Electrical Power Networks Using Intelligent Techniques

Alimorad Khajehzadeh¹, Reza Seyedi Marghaki²

¹ Department of Electrical Engineering, Kerman Branch, Islamic Azad University, Kerman, Iran

² Department of Electrical Engineering, Kerman Branch, Islamic Azad University, Kerman, Iran

Abstract

In this study intelligent hybrid formalism is presented to recognize faults in electrical power networks. The accurate and automatic recognition of faults in electrical power networks has vital importance. The goal of accurate and automatic recognition of faults in electrical power networks is to control and monitor the system that giving a security to final users for stable voltage and normal condition. To solve the fault recognition problem in power networks, it has been considered an hybrid use among optimization, state space and analytical approach by building a algorithm for its solution. The state space can determine the accurate direction of disturbance. The final task in fault recognition is done by optimization module and analytical module. In the proposed method, the location and class will be determined. To test the performance of proposed hybrid method, we used some electrical power networks. The obtained results show that the proposed method has high accuracy in fault recognition of electrical power networks.

Keywords: *State space, fault, power network, optimization, recognition.*

1. Introduction

The main target of electrical power network is to keep uninterrupted services, and to reduce the outage time. When unusual situation occur in the network, it is actually inconceivable to avoid series a innate adventures, physical events, equipment defect, that led to the loss of active power generation and voltage sag in the power network. As faults happen in the power network, they usually provide noticeable transitions in network variables such as current magnitude in lines, active and reactive power level, power factor value, impedance matrix, frequency value and voltage phase and voltage magnitude. The electrical power network protection is the skill of

using and setting up relays, breakers, switches or fuses or all of them, to guarantee maximum delicacy to fault occurrence and unnatural situations. Therefore it is ideal that a proper decision be made by the protective tool as to whether the fault is an unnatural situations or only a transient which the system may attract and return to standard steady state situation [1- 6].

The power network fault recognition by Kalman filter method is introduced in [1]. In [2], information based fault detection is applied for electrical power network. The state approximation for usual electric power network was introduced in [3]. The new model-based fault detection system for nonlinear and complicated dynamic power networks with physical uncertainties is proposed in [4]. In [5], measurement nodes belonging to monitor loop chains including of controller unit, actuator sections, tool under control and devices are assumed for investigate of fault recognition and isolation in accurate and automatic system by analytical methods. All of these rules and basis are constructed on clear power system structure taking into worst-instance fault situations. The settings defined using the traditional techniques have innate limitations in recognizing certain patterns if the power system actual structure deviates from the anticipated one. In these cases, the available relays can miss operate [6]. Thereupon, a furthermore dependable and safe relaying principle is necessary for recognizing the faults under a difference of time-varying power system structures and accidents.

A number of techniques have been introduced in the papers for secure and fast identification of faults. The monitoring term of electric power networks is therefore very effective in the fast recognition of component failure that would lead to more suitable operational safety and economy. In [7] correlation study among transmitted and returned wave shapes is done, whereas in [8] peak

recognition on the returned wave shape is applied to detect possible fault position base on the delays approximated. A weakness of these techniques is the demand of measuring tools with a noticeable great sampling rate. Beside, impedance based techniques works on steady states magnitudes of line currents and terminal voltages through the fault occurrence to approximate an apparent impedance that is straightly related to a interval to the fault. The main weakness of impedance-based techniques is the multi- approximation due to the existence of several possible faulty locations at the same interval [9- 16].

This study introduces an intelligent system for extension of alarms signal and fault location approximation, where problem is divided in two sections, one at network side level, in device to recognize the region or district, and the second section at system level helping to recognize the positions were affected by a special contingency. The first part is performed on state space concept that it is introduced a mathematical pattern to solve question of alarm controlling at tool level in order to search a locally optimal answer of best situation. The second module is based on a mathematical pattern that applies optimization and analytical pattern knowledge from previous module and knowledge that describes configuration of system globally. The proposed method is applied to accurately recognize the faults those commonly happen in electrical power networks.

2. Problem description

In this study a strategy that state space module, optimization module and analytical modules are complementary to find the final solution of fault detection in power networks. As the innovation feature of this study has been introduced with a functional device to self-training inputs that have the straightforward to adapt to new knowledge, there is refreshing of dataset reveals no essential to shift the variable settings. Figure1 illustrate the main structure of the introduced technique. The introduced technique is activated as soon as a situation of unnatural operation of an electrical power network is recognized using signaling alarms, line breakers and related relays. This device is supplied with all effective knowledge related with occurrence, to characterize the accident more accurately. Therefore, alarms achieved from the network output supply knowledge concerning the trip of relays and mood of line breakers. The knowledge around relays tripping is investigated by state space module, and line breakers knowledge along with output of state space module are manipulated by optimization

module and analytical module, that in turn generate the detection for happen fault [17- 25].

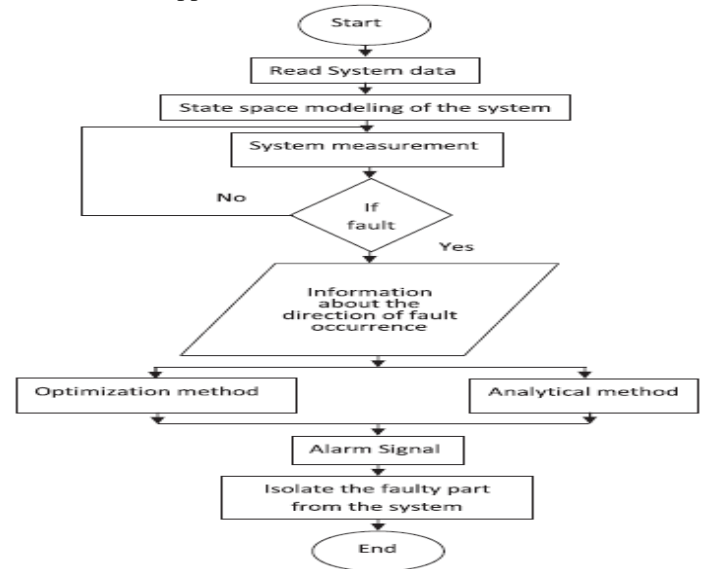

Fig1. The proposed method scheme

Each dynamic system is defined mathematically by a collection of equations of the below form:

$$\dot{x} = g(x, v, T_m, t) \quad (1)$$

That x displays system state vector, T shows mechanical moment of system, t displays time and vector v is a vector of voltages magnitude and voltage phase where consist of v_d, v_q and v_F . The target is to extract relation among v_{di} and v_{qi} , $i=1,2,\dots,n$, and the system state parameters. It will be gained in the form of a relation among these voltage magnitudes and voltage phases, the network currents i_{di} and the related phases δ_i , $i=1,2,\dots,n$. In the example of magnetic flux linkage instance the current magnitudes are linear hybrid of the magnetic flux linkages. For comfortable it will apply a hybrid notation described as follow for system i , it is describe the phase and magnitude of voltage and current as follow:

$$\bar{V}_i = V_{qi} + iV_{di} \quad (2)$$

$$\bar{I}_i = I_{qi} + iI_{di} \quad (3)$$

That the q_i axis is gained as the reference signal in each instance. The voltage and current \bar{V}_i and \bar{I}_i are referred to the q and d vector of system i . The favorite relation is that which relate the vector V (Voltage) and I (Current). From the electrical power system steady state formulations, it can be described:

$$\hat{I} = Y\bar{V} \quad (4)$$

That these variables are defined as follow:

$$\bar{I} = \begin{bmatrix} \bar{I}_1 \\ \bar{I}_2 \\ \dots \\ \bar{I}_n \end{bmatrix} \quad (5)$$

$$\bar{V} = \begin{bmatrix} \bar{V}_1 \\ \bar{V}_2 \\ \dots \\ \bar{V}_n \end{bmatrix} \quad (6)$$

$$\bar{Y} = \begin{bmatrix} Y_{11}e^{j\theta_{11}} & Y_{12}e^{j\theta_{12}} & \dots & Y_{1n}e^{j\theta_{1n}} \\ Y_{21}e^{j\theta_{21}} & Y_{22}e^{j\theta_{22}} & \dots & Y_{2n}e^{j\theta_{2n}} \\ \dots & \dots & \dots & \dots \\ Y_{n1}e^{j\theta_{n1}} & Y_{n2}e^{j\theta_{n2}} & \dots & Y_{nn}e^{j\theta_{nn}} \end{bmatrix} \quad (7)$$

If, $\delta_i = \delta_{i0} + \delta_{i\Delta}$ then:

$$\bar{M} = \begin{bmatrix} Y_{11}e^{j\theta_{11}} & Y_{12}e^{j(\theta_{12}-\delta_{11}-\delta_{12})} & \dots & Y_{1n}e^{j(\theta_{1n}-\delta_{11}-\delta_{1n})} \\ \dots & \dots & \dots & \dots \\ Y_{m1}e^{j(\theta_{m1}-\delta_{m1}-\delta_{m1})} & Y_{m2}e^{j(\theta_{m2}-\delta_{m1}-\delta_{m2})} & \dots & Y_{mn}e^{j\theta_{mn}} \end{bmatrix} \quad (9)$$

The final result of the state space module for normal condition and faulty situation may be illustrated by figure 2. This figure shows the selection of parameters may be divided into 2 sections, that may be called as expected and unexpected parameters. In this figure, expected parameters are put into section one and unexpected parameters have been kept in section two. It exploited that as network run in normal situation, the parameters related to normal condition running may be described as expected parameters. Unexpected parameters illustrate the network is in disturbed or faulty situation [15].

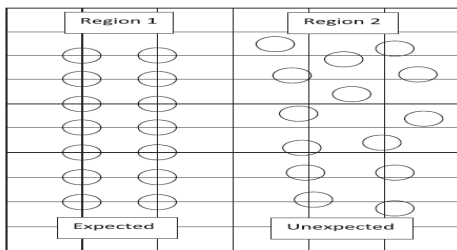

Fig 2. Recognition of parameters by 2 index

State approximation algorithms with optimization methods are essential in electric power networks to led precise approximation of the system state, as the measurement dataset is corrupted by one or more parameters. Several optimization methods have been introduced, such as gradient descend algorithm, back propagation method, iterative least squares algorithms and many others. A new technique has been introduced in this study, that have been relates with a tolerance

boundary with each variables. An integer planning issue is a special instance of optimization questions, whose parameters may just take integer magnitudes. A hybrid integer planning issue is another special instance that several but not all the parameters are limited to be integers [26- 33].

A model of this type of optimization mood points occurs as parameters of problem are limited to only 2 values. The best power flow computation have been established and solved by the hybrid integer nonlinear programming algorithm. The approximation index applied is to choose a state estimate that reduce the general number of measurement parameters, independent variables and power line states which are assumed out of oscillation, that may be defined as follow:

$$\text{Minimum } \sum_{ij} Z_{Tij} \quad (10)$$

The network for the transmission of electric energy is modeled via the power balance equation at each node in the system. These include the usual load flow equations at each node and the power balance equations, as given below.

$$P_{gi} - P_{di} = \sum_{j=1}^{n_i} A_{ji} P_{ij} \quad (11)$$

$$Q_{gi} - Q_{di} = \sum_{j=1}^{n_i} A_{ji} Q_{ij} \quad (12)$$

Each variable could be defined using a couple of inequality limits based on the upper and lower boundaries of oscillation for that measurement variables. More details regarding the computations can be found in [31].

3. Introduction to analytical hierarchy process

The analytical hierarchy process is proposed in [32]. The analytical hierarchy process is a decision-making concept, that aids in searching targets or goals between alternative courses of action. It is a classic technique for comparing a roster of targets and the superseded solutions satisfying respective targets. Initially, couple wise comparisons are make among the targets and, then, among superseded solutions with respect to each target. For couple wise comparison, several weights are also determined according to the matter, or preference of the targets or the superseded. A comparison of targets/ superseded are listed in table 1.

Table 1:Relative matter of variables

1	Target i and j are of equally importance
3	Target i is weakly much matter than j
5	Target i is strongly much matter than j
7	Target i is high strongly much matter than j
9	Target i is extensively much matter than j
2, 4, 6, 8	Target i is extensively much matter than j

Assuming a decision-making question to prioritize m superseded by n goals, the analytical hierarchy process method has been illustrated in Table 2.

Table 2: comparison matrix of targets for couple wise.

	T_1	T_2	...	T_n	Priority
T_1	c_{11}	c_{12}	...	c_{1n}	p_1
T_2	c_{21}	c_{22}	...	c_{2n}	p_2
...
T_n	c_{n1}	c_{n2}	...	c_{nn}	p_n

The associative weights of targets may be calculated as normalized geometric means of the rows. The geometric means are calculated by:

$$h_i = \sqrt[n]{\prod_{k=1}^n c_{ik}} \quad (13)$$

The associative weight of the i th target is computed by:

$$P_i = \frac{h_i}{\sum_{i=1}^n h_i} \quad (14)$$

This study describes the introduced method for determining the placement of the faults, based on analytical hierarchy process method. The vital difficulty is to select the much better places, when 6 parameters are investigated. For instance, a special option can have the greatest oscillations in the synchronous generator phases, another with real power and reactive power injection form nodes, and another with voltage phases at remaining terminals. A decision selecting techniques is the vital key for deciding which options must be selected. Using the several parameters for fault identification in the network can be desired at the initial glance but because of tools prices, unavailable science, repair, maintenance issues and so on is not desired. Then the parameters, that recognizes the more probable faults to minimize fault occurrence is very vital issue. According to knowledge around these parameters, fault occurrence in the network may be reduced. Then more suitable faults in the network make known by analytical hierarchy process technique, where intent has been chosen based on some valuable parameters that are quantities or qualities. The hierarchical intent choosing scheme for fault recognition with n number of parameters and their effectiveness on different terminals in the network as illustrated in figure 3. Solving a question with these several parameters becomes tedious action by mathematical investigation, but using this technique it becomes easy and applicable to know around fault occurrences in the power network.

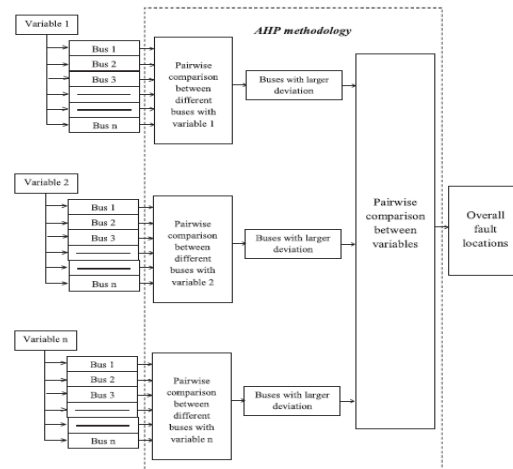

Fig.3. Flowchart of proposed method

4. Simulation results

The introduced method has been evaluated on IEEE-9 node network. This power network includes of three synchronous generators, 9 terminals, and 9 power lines. The figure 4 illustrates the single line diagram of the test network [33]. The proposed method estimates the interconnection of synchronous generators and terminals through the power lines. In the simulations, the second generator is fixed at 163 Mega Watts and third generator is fixed at 85 Mega Watts. These capacities are achieved as the threshold magnitude for which the network remains stable for the most extensive fault.

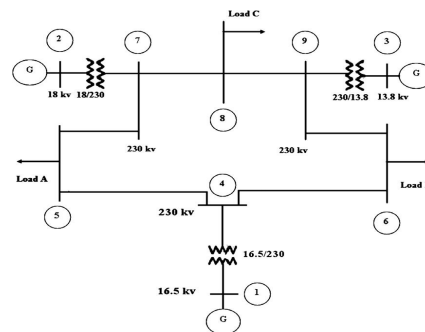

Fig4. The test system diagram

Several of scenarios are assumed where fault happens in the power network at various locations to evaluate the introduced method. State space description of the electrical power network may be defined as, first generator (traditional model)

$$\tau_k \dot{\omega}_k = T_{mk} - E_{qk} I_{qk} - D_k \omega_k \quad (15)$$

$$\dot{\delta}_k = \omega_k \quad (16)$$

Second and third generators:

$$\tau_{qk} \dot{E}_{dk} = E_{dk} - (x_{qk} - x'_k) I_{qk} \quad (17)$$

$$\tau_{qk} \dot{E}'_{dk} = E'_{Fdk} - E'_{dk} + (x_{dk} - x'_k) I_{qk} \quad (18)$$

$$\tau_{jk} \dot{\omega}_k = T_{nk} - D_k \omega_k - I_{dk0} E'_{dk} - I_{qk0} E'_{qk} - E'_{dk0} I_{qk} - E'_{qk0} I_{qk} \quad (19)$$

$$\dot{\delta}_k = \omega_k \quad (20)$$

That $k = 2, 3$ to gain an independent set. Also:

$$\dot{\delta}_i = \omega_i \quad (21)$$

The final state space system comprises 9 linear 1-order differential equations dynamic. The state space independent variables are as follow:

$E'_{q2}, \omega_1, E'_{q3}, \omega_2, E'_{d2}, \omega_3, \delta_{13}, \delta_{12}$ and E'_{d3} . The electrical power network is defined using the following equations:

$$x = [\omega_1; E'_{q2}; E'_{d2}; \omega_2; E'_{d3}; E'_{q3}; \delta_{13}; \delta_{12}; \omega_3] \quad (22)$$

$$u = [T_{n1}; E_{FD2}; T_{n2}; E_{FD3}; T_{n3}] \quad (23)$$

State space parameters are able to recognize synchronous generator phase, rotating velocity and voltage magnitude, etc. The primary magnitudes of these state space parameters are as follow:

$$\omega_1 = 1; E'_{q2} = 0.78; E'_{d2} = -0.69; \omega_2 = 1; E'_{d3} = -0.66; E'_{q3} = 0.76; \delta_{13} = 0.90; \delta_{12} = 1.02; \omega_3 = 1$$

The power network parameters have been selected with fault free situation. Figure 5 illustrates the state space parameters in P.U. with respect to time domain. It illustrates the normal action of the power network. From this figure, it may be seen that each of the state space parameters is stable with respect to time domain. Therefore, the network is found to be stable.

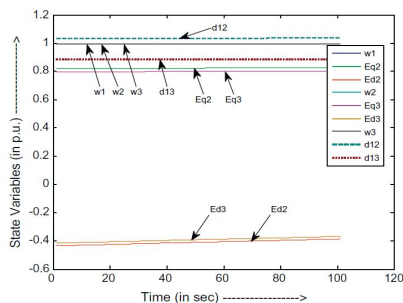

Fig.5. State space parameters time domain (Normal situation).

Power line fault is one of the usual faults that are usually occurred in the power networks. Here, the power network parameters have been chosen with power line fault. A3-phase faults have been assumed close to terminal (No. 7) at the end of power line 5 through 7. The figure 6 illustrates the state space parameters in P.U. with respect to time domain with this faulted situation. In this condition, the power network does not follow the normal manner. It may be seen from this figure which the synchronous generator phase δ_{12} will increase without any constraints. The oscillation in δ_{12} is much more than δ_{13} , therefore, from this figure it may be seen that fault has happen in the power network close to node No. 2, and power network is going to be unstable network. It shows the orientation of fault occurrence is close to terminal No. 2. It is obvious from this figure that the final load phase slips return as a result of the increase in the bus voltage magnitude. This is because of the truth that as the voltage magnitude increases, the node power increases and as the input power remains fixed value, the increase in the node power is met by drop of the kinetic energy stored in the rotor axis, therefore the slipping return of the rotor phase. The slipping return of the load phase is accompanied by a decrease in the velocity, but as the unit is on hook to an infinite terminal, the velocity recovers to that of the infinite terminal and thus no variation in the velocity happens at steady state condition.

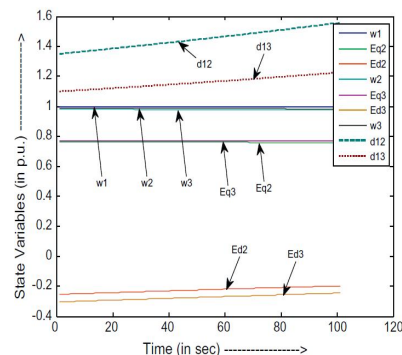

Fig 6. State space parameters in time domain (abnormal situation).

The line lost subject has been investigated in the network, it has been assumed among terminal 4 and terminal 6. The figure 7 illustrates the state space parameters in P.U. with respect to time domain with this faulted situation. It may be seen that the power network performance does not follow the normal manner. Figure 7 represents the oscillation in δ_{13} is higher than δ_{12} . It may be concluded that fault has happened in the power network close to node 3.

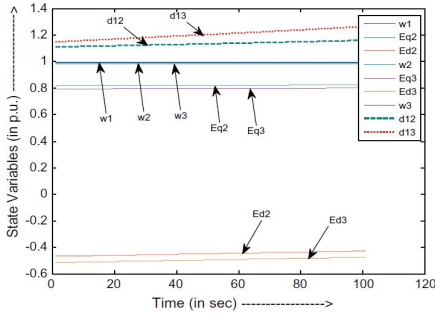

Fig.7. State space parameters in time domain (line lost situation).

The synchronous generator outage has been taken as on terminal 3. The figure 8 illustrates the state space parameters in P.U. with respect to time domain with this faulted situation. It may be seen that the power network oscillates from their normal condition of power network. From this figure, the synchronous generator phase δ_{13} will decrease without term and it may be seen that fault has happened in the network close to terminal 3. It may be concluded, that as phase becomes decreases, then synchronous generator fault is there in the network.

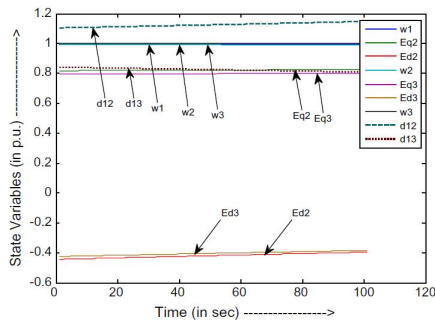

Fig.8. State space parameters in time domain (generator fault situation).

It is obvious from these plotted figures that the faults have been happened in the special orientation close to some terminals but, yet it is not chosen that precisely on which terminal fault has happened and which model of faults in the network. For synchronous generators and power lines, the possible detections are defect, no defect, and defect side, that is not situated in close of part analyzed. Relays related with protection node-bars are unable to represent the position of fault. Therefore, state space representation will only detection fault or not fault in the power network. At this step the protection philosophy is applied to enter setup of studied network into integer programming. Therefore, the defined function of integer programming is to investigate logic protection of network in an integrated procedure. For this purpose, outputs of state space

representation and mood of breakers are assumed. The question may be readily solved by traditional mathematical programming environment, for example the MINLP algorithm [34]. The introduced technique is therefore associated to the branch and bound technique [35]. A exact load flow computation have been gained, with several independent operating situation and the variables such as voltage value and phase as listed Table 3. Measurement variables and state space parameter insecurity ranges were then described, as shown in 6th and 7th columns of this table. The solution of the hybrid integer program gave the oscillation of faulty situation with standard (Normal) situation as listed in Table 3. The oscillations have been recognized and corrected. It may be detected that the phase oscillation is 12.9 that crosses the deviation magnitude, has value of one.

Table 3: Performance for various operating situation by optimization technique in presence of generator fault.

Node No.	Normal situation		Abnormal situation		Oscillation	
	Voltage magnitude	Phase	Voltage magnitude	Phase	Voltage magnitude	Phase
1	1.041	0	1.041	0	0	0
2	1.041	9.081	1.001	2.655	0.041	6.433
3	1.031	4.71	1.001	-8.271	0.031	12.973
4	1.043	-2.132	1.022	-4.846	0.022	2.713
5	1.013	-3.823	0.988	-8.167	0.026	4.346
6	1.028	-3.535	1.002	-9.038	0.029	5.502
7	1.040	3.687	1.001	-3.177	0.038	6.866
8	1.028	0.799	0.991	-7.676	0.038	8.476
9	1.041	2.044	1.005	-5.271	0.035	7.312

5. Conclusion

This study describes a technique to solve the question of alarm processing and defect location approximation at control system level using of integration of 3 methods that is state space model description, optimization module and analytical investigation. A state space model description method was applied with the goal to infer, based on trip signal vectors of relays, that instrument protections operated, therefore directing the defect allocation. Using this method it was possible valuably decrease the number of alarms related with the equipment protection relays, taking benefit of the possibility of generating a common model for each array, and active and reactive power transformer, power line or node-bar. The optimization module and analytical methods were applied to show the philosophy of protection as a whole connecting the output of the state space definition associated the breakers. Using

of this it was possible to define how the protections of the different power system tools sighted the fault in a fault indicating its position. It may be simply extended to incorporate more plant parts, is easy to apply and to understand.

- [1] L.S. Titare. Optimal reactive power rescheduling based on EPSDE algorithm to enhance static voltage stability. *Electrical Power and Energy Systems* 63 (2015) 588–599
- [2] H. Raoufi and M. Kalantar, “Reactive Power Rescheduling with Generator Ranking for Voltage Stability Improvement,” *Energy Conversion and Management*, vol. 50, pp. 1129–1135, 2013.
- [3] Omid Alizadeh Mousavi. Investigation of P–V and V–Q based optimization methods for voltage and reactive power analysis. *Electrical Power and Energy Systems* 63 (2014) 769–778
- [4] B. Zhao, C. X. Guo and Y. J. Cao “A Multiagent-Based Particle Swarm Optimization Approach for Reactive Power Dispatch ” *IEEE Transactions on Power Systems*, vol. 20, no. 2, pp. 1070-1078, 2014.
A. A. Esmiin, G. Lambert-Torres, and C. Z. Souza “A Hybrid Particle Swarm Optimization Applied to Loss Power Minimization,” *IEEE Transactions on Power Systems*, vol. 20, no. 2, pp. 859-866, 2014.
- [5] M. Varadarajan and K. S. Swarup, “Differential evolutionary algorithm for optimal reactive power dispatch,” *Electrical Power and Energy Systems*, vol. 30, pp. 435–441, 2013
- [6] W. Zhang, and Y. Liu, “Multi-Objective Reactive Power and Voltage Control Based on Fuzzy Optimization Strategy and Fuzzy Adaptive Particle Swarm,” *Electric Power Systems Research*, vol. 30, pp. 525–532, 2012.
- [7] F. Dong, B. H. Chowdhury, M. L. Crow, and L. Acer “Dynamic Security Constrained Optimal Power Flow/Var Planning,” *IEEE Transactions on Power Systems*, vol. 16, no. 1, pp. 38-43, 2011.
- [8] Rodrigo Moreno. A MILP model for optimising multi-service portfolios of distributed energy storage. *Applied Energy* (2014) 189-198
- [9] F. Dong, B. H. Chowdhury, M. L. Crow, and L. Acer “Improving Voltage Stability by Reactive Power Reserve Management,” *IEEE Transactions on Power Systems*, vol. 20, no. 1, pp. 338-345, 2013.
- [10] M. A. Abido, and J. M. Bakhshwain, “Optimal VAR dispatch using a multiobjective evolutionary algorithm,” *Electric Power Systems Research*, vol. 27, pp. 13–20, 2014.
- [11] M. A. Abido, and J. M. Bakhshwain, “Optimal VAR dispatch using a multiobjective evolutionary algorithm,” *Electric Power Systems Research*, vol. 27, pp. 13–20, 2013.
- [12] Benyamin Khorramdel. Optimal stochastic reactive power scheduling in a microgrid considering voltage droop scheme of DGs and uncertainty of wind farms. *Energy* 45 (2012) 994e1006
- [13] Mozafari, B., Ranjbar, A. M., Shirani, A. R., and Mozafari, A. Reactive Power Management in A deregulated Power systems with considering Voltage stability :particle swarm optimisation Approach. *International Conference on Electricity Distribution*, 6-9. (2013).
- [14] A.K. Singh. A multiple strategic evaluation for fault detection in electrical power system. *Electrical Power and Energy Systems* 48 (2013) 21–30.
- [15] M.R. Banaei. Dynamic stability enhancement of power system based on a typical unified power flow controllers using imperialist competitive algorithm. *Ain Shams Engineering Journal* (2014) 5, 691–702
- [16] S. Sreejith, Sishaj P. Simon, M.P. Selvan. Analysis of FACTS devices on Security Constrained Unit Commitment problem. *International Journal of Electrical Power & Energy Systems*, Volume 66, March 2015, Pages 280-293
- [17] Samo Gasperic, Rafael Mihalic. The impact of serial controllable FACTS devices on voltage stability. *International Journal of Electrical Power & Energy Systems*, Volume 64, January 2015, Pages 1040-1048.
- [18] Biplob Bhattacharyya. Fuzzy based evolutionary algorithm for reactive power optimization with FACTS devices. *Electrical Power and Energy Systems* 61 (2014) 39–47
- [19] Mohsen Gitizadeh. A new method for SVC placement considering FSS limit and SVC investment cost. *Electrical Power and Energy Systems* 53 (2013) 900–908.
- [20] J.S. Huang. Loadability of power systems and optimal SVC placement. *Electrical Power and Energy Systems* 45 (2013) 167–174.
- [21] Astrom KJ, Hagglund T. *Advanced PID control*. Research Triangle Park (NC): ISA-The Instrumentation, Systems, and Automation Society; 2012.
- [22] Visioli A. *Practical PID control*. London: Springer; 2012.
- [23] Kano M, Ogawa M. The state of art in advanced process control in Japan. In: *IFAC symposium ADCHEM*. Istanbul (Turkey); 2013.
- [24] Johnson MA, Moradi MH, Crowe J. *PID control: new identification and design methods*. Berlin: Springer; 2013.
- [25] Seborg D, Edgar T, Mellichamp D. *Process dynamics and control*. 2nd ed. New York (USA): John Wiley; 2012.
- [26] Hongqing Fang. Application of an improved PSO algorithm to optimal tuning of PID gains for water turbine governor. *Energy Conversion and Management* 52 (2013) 1763–1770
- [27] Goshal, S. P. (2012). Optimization of PID gains by particle swarm optimization in fuzzy based automatic generation control. *Electric Power System Research*, 72, 203–212.

- [28] Shatirah Akib. Application of ANFIS and LR in prediction of scour depth in bridges. *Computers & Fluids* 91 (2014) 77–86
- [29] Morteza Tofighi. Direct adaptive power system stabilizer design using fuzzy waveletneural network with self-recurrent consequent part. *Applied Soft Computing* 28 (2015) 514–526
- [30] Kumar Abhishek. Comparing Predictability of Genetic Programming and ANFIS on Drilling Performance Modeling for GFRP Composites. *Procedia Materials Science* 6 (2014) 544 – 550
- [31] L. Yang. Performance prediction of a hybrid microgeneration system using Adaptive Neuro-Fuzzy Inference System (ANFIS) technique. *Applied Energy* 134 (2014) 197–203.
- [32] E. Avci, D. Hanbay, A. Varol. An expert Discrete Wavelet Adaptive Network Based Fuzzy Inference System for digital modulation recognition. *Expert Systems with Applications* 2013; 33: 582–589
- [33] NEOS, NEOS Server for Optimization; 2008. <<http://neos.mcs.anl.gov/neos>>.
- [34] Monticelli A. State estimation in electric power systems – a generalized approach. Norwell, MA: Kluwer; 2013.