

Performance of MIMO VBLAST-OFDM in Ka-Band

¹S.FEROUANI, ²G.ABDELLAOUI, ³F.DEBBATE, ⁴FT.BENDIMERAD

^{1,2,3,4}Departments of Electrical Engineering and Electronics, Tlemcen University, Algeria

Abstract

Technological advances have allowed the use of Ka-band for transmission in 30 GHz uplink and 20 GHz at downlink. The use of Ka-band has advantages over lower frequency bands; it allows a wider bandwidth and therefore a greater flow to pass. In addition, multibeam technology allows a wide reuse frequency, thereby reducing significantly the cost of the spectrum. In this Ka-band (20-30 GHz), quality of service can be degraded by the effects of effects of propagation through the atmosphere. We have proposed in this paper the MIMO OFDM-VBLAST technique for Ka-band application to improve performance. The simulation is based on the study of effect of the channel attenuation (rain and gas) in the Ka-band signal. The simulation results show the importance of using our proposal, where performance is determined in terms of bit error rate BER.

Keywords: MIMO Systems, Ka band, OFDM Modulation, Satellite Transmission.

1. INTRODUCTION

In the context of future satellite communications systems, deployment of Ka-band presents a necessity [1], particularly because of the saturation bands L, C and Ku. This operation offers the advantage of wider channels that support a greater number of users. It also reduces the size of the user terminal as well as those of the antenna. Nevertheless, the exploitation of the Ka-band is accompanied by certain disadvantages mainly associated with more severe propagation conditions. In comparison with the Ku band, the Ka-band signal received may be subject to strong attenuations result of weather disturbances. For example, Ka-band attenuation can exceed ten dB following heavy rainfall to overcome these problems; a MIMO diversity technique is used [2]. The transmission channel is the central problem that must be addressed in different transmission solutions proposed. When sending a symbol through the channel, it will be received in the form of delayed and attenuated versions super imposed, which can generate interference between symbols transmitted, for this we must use techniques such as transmission TDMA, FDMA, CDAMA, OFDM and MC-CDMA.

To maintain high flows and cancel the interference between symbols, we studied the association of the technology MIMO with OFDM Modulation, which consists of a parallel transmission of data with sufficiently long periods, and we also introduce the coding VBLAST to ensure the quality of transmission.

This technique is widely used in wireless networks such as WIFI (802.11n), WIMAX, and it can also be used for satellite transmission (DVB-S2, DVB-SH...).

Our study is based on first point on the architecture of MIMO-OFDM, in second point the encoding and decoding VBLAST applied to the signals, and in thirist point the characteristics of the Ka-band satellite transmission. Finally, simulation results of our study which clearly show the improvement provided by the MIMO-OFDM.

2. MIMO-OFDM SYSTEM

Increasing of the size modulations or the frequency band used are the only solutions to increase the flow of data in a single antennas system. In multi antenna MIMO, the capacity Increases linearly with the number of transmitting antenna, exceeding the theoretic limit of Shannon [3]. The systems have an additional advantage because they resist fading and interference.

MIMO-systems are considered as a technology capable of solving the problems of congestion and capacity limitations of wireless broadband networks.

2.1 MIMO device

Fig.1 shows the pattern of transmission MIMO (Multiple input Multiple output); it is to send packets to different antennas that emit at the same frequency. Upon receiving the signals are combined and processed by a processor MIMO containing very powerful calculate algorithms.

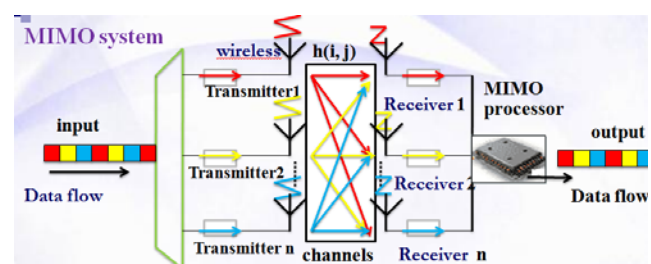

Fig.1: MIMO device

Channel capacity is given by:

$$C = \log_2 \det \left[I_N + \frac{\rho}{M} H H^* \right] \quad (1)$$

H: the complex gain of the channel.

M: MIMO block size.

ρ : average SNR.

C: channel capacity in bps / Hz.

2.2 Modeling of a MIMO-OFDM:

We consider a MIMO system using OFDM modulation, where the transmitter and receiver are provided respectively with N_t and N_r antennas.

The antennas are disposed of the most commonly used, known in English Uniform Linear Array (ULA) [4], that is to say they are aligned and evenly spaced. The relative distance between two adjacent antennas is given by:

$$\Delta = 1 / 2 \lambda \tag{2}$$

Where λ is the wavelength.

Fig 2 describes the diagram of a MIMO / OFDM; in transmission we have the following stages:

- Serial parallel conversion of P size to obtain blocks of P symbols.
- Inverse Fourier transform of P size.
- Inserting a guard interval of D size at the beginning of the end block where the block is copied.

In reception, the dual operations are performed:

- Conversion parallel series.
- Conversion series parallel of P size to obtain blocks of $P + \Delta$ symbols.
- Remove the guard interval corresponding to the first samples of the block.
- Direct Fourier Transform of P size.
- Conversion parallel series.

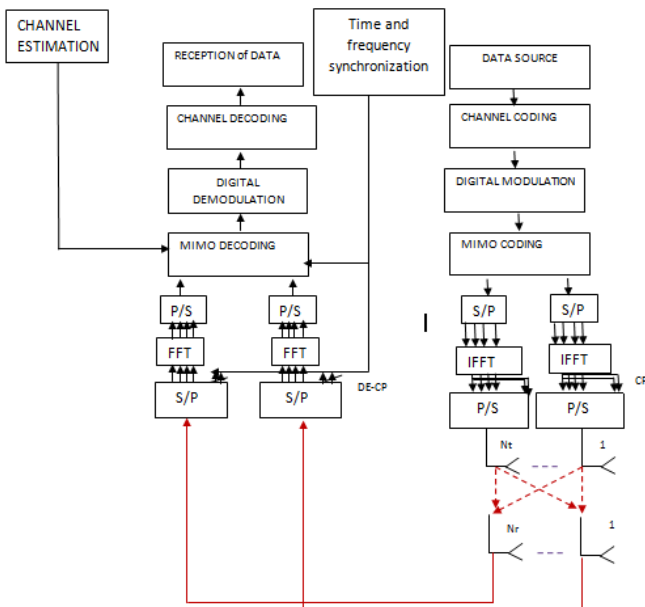

Fig.2: Model of MIMO-OFDM ($N_t \times N_r$) system

3. VBLAST-OFDM Coding

The coding principle VBLAST is to transmit each N_t time [5].

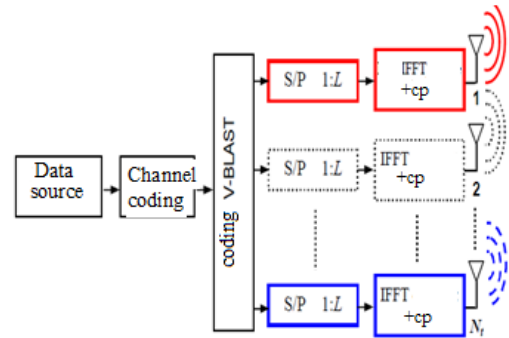

Fig.3: VBLAST-OFDM Transmitter

4. VBLAST-OFDM Decoding

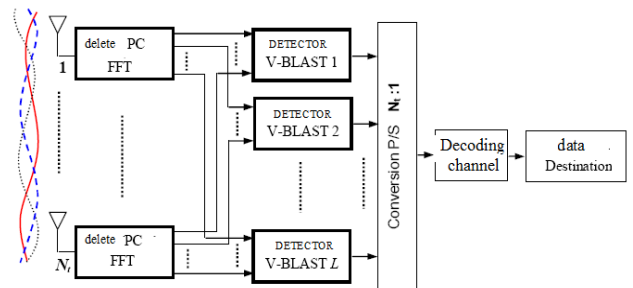

Fig.4: VBLAST-OFDM Receiver

Fig.4 shows the block diagram of a receiver V-BLAST-OFDM. Each receiving antenna receives a signal for each of the L sub channels [5]. After the cyclic prefix is removed, each received signal is passed through a block FFT operation for demodulation.

The received signal after demodulation at the receiving antenna j for sub-channel l is given by:

$$y_{j,l} = \sum_{i=1}^{N_t} H_{j,i,l} x_{i,l} + n_{j,l} \tag{3}$$

where $h_{i,j,l}$ is the normal path complex gain of transmitting antenna i to receive antenna j at the frequency l , $x_{i,l}$ is the OFDM symbol transmitted from antenna i at frequency l , and the n_j are independent Gaussian noise samples. The outputs of FFT blocks are passed through the L -VBLAST detectors, each with N_r inputs, and N_t outputs. The outputs of the VBLAST detectors are converted to sub-parallel streams into a single serial stream of data. Finally, the data is decoded by the channel decoder.

5. OFDM Modulation and demodulation

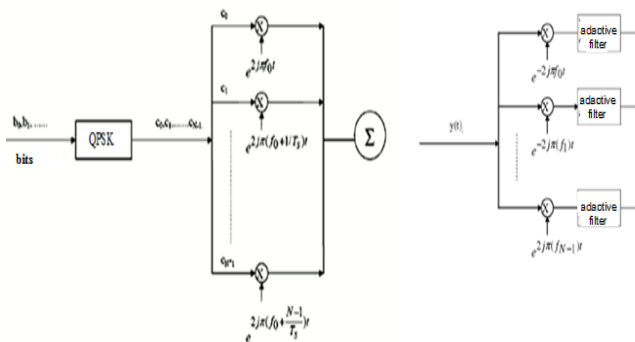

Fig.5: Diagram of OFDM modulation and demodulation

To distribute the data to be transmitted on the N carriers, symbols are grouped in bundles of N. The complex numbers c_k are defined [6] from the bits by a constellation often QAM and PSK:

$$c_k e^{j2\pi f_k t} \quad (4)$$

The total signal $s(t)$ is the set of N symbols reassembled in an OFDM symbol:

$$S(t) = \sum_{K=0}^{N-1} c_K e^{j2\pi f_K t} \quad (5)$$

The received signal is written over symbol duration T_s :

$$y(t) = \sum_{K=0}^{N-1} c_K H_K(t) e^{2j\pi(f_0 + K/T_s)t} \quad (6)$$

$H_K(t)$ Is the channel transfer function around the frequency and time t.

6. KA-Band propagation

With the use of Ka band frequency, atmospheric phenomena frequency, related to wave propagation, become very important and severely limit system performance. These mitigations, contributing heavily to the degradation of satellite signals in the Ka band, are caused by atmospheric gases, clouds and precipitation [7]. The rain is the dominant phenomenon of attenuation in the frequency bands above 10GHz (ex Ku, Ka) causing significant decreases in signal quality.

6.1 KA-Band attenuation

The rain is the phenomena that most affects the quality of Ka-band signals which we studied its decay with the gas in this article:

6.1.1 Attenuation by rain

- Rain causes absorption and scattering that give rise to a weakening depends on the intensity of the precipitation and the frequency.

- The relationship between the linear attenuation γ_R (dB/Km) and intensity of rainfall R(mm/h) given by ITU-RP :

$$\gamma_R = a \cdot R^b \quad (7)$$

Table I: a and b for different frequencies

F(GHz)	a	b
1	0.000038	0.912
10	0.0101	1.276
20	0.0751	1.099
30	0.187	1.021
40	0.350	0.939

Fig.6 shows an example of a time series of attenuation by rain in the Ka band (measured for a fixed point on the ground).

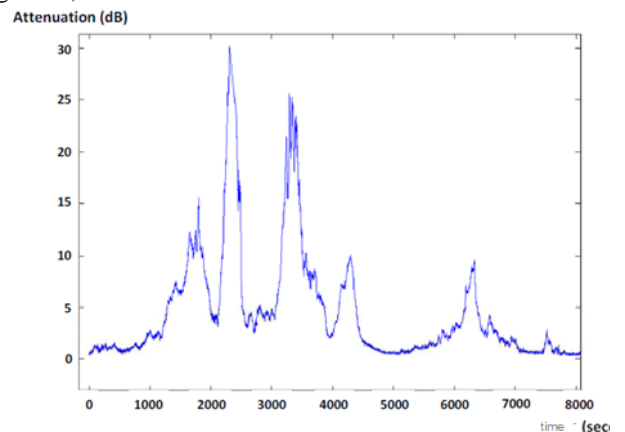

Fig.6: Example of time series of rain attenuation in Ka band.

6.1.2 Attenuation due to gas

Oxygen, in particular, is the gas component that most affects the quality of Ka band signal. Its effect is more substantial at low temperature. For example, in a Europe a climate and at a frequency of 30 GHz the oxygen attenuation average is around 0.2 dB.

8. Simulations:

This section presents the results of simulations of the system proposed in this paper (MIMO-OFDM-BLAST); improvement brought by the use of this combination in the Ka band is shown in the figures in terms of BER.

8.1 Simulation Parameters

The main characteristics of a Ka band satellite channel are the atmospheric attenuations (gas and rain), that we introduce in our simulations.

We chose frequency of 29.7 GHz which is included in the interval [20, 30] GHz, an elevation of 10°, latitude of 70 degrees, a concentration of water vapor from 20g/m³.

The evaluation of a communication system transmission quality is represented by two variables: the BER (Bit-Error-rate) and SNR (Signal to noise).

- The type of modulation used is QPSK,
- The number of OFDM subcarriers is 512
- The number of pilot OFDM is 32.
- N_t (number of transmit antennas) is equal to N_r (number of receive antennas) is 2 and 4 respectively.

8.2 Performance systems

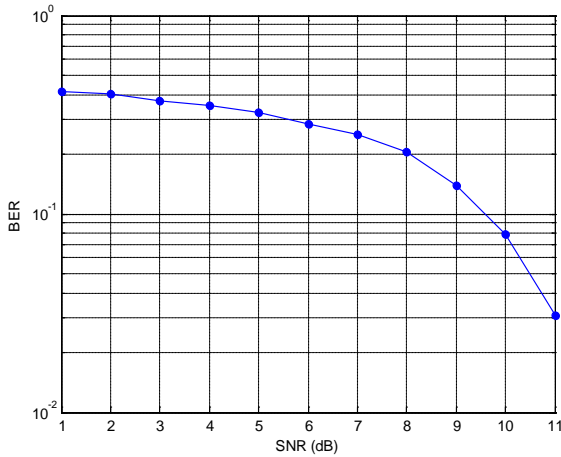

Fig.7: SISO-OFDM in Ka-band

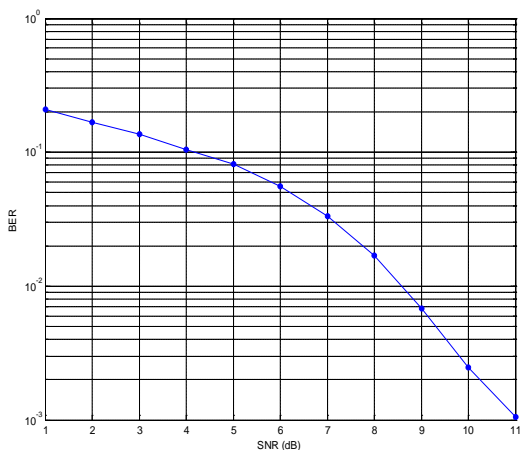

Fig.8: SIMO-OFDM in Ka band
 nt=1, nr=2

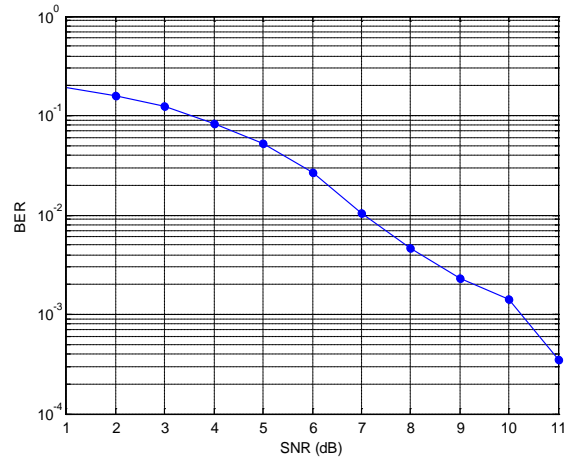

Fig.9: MIMO-OFDM in Ka band
 nt=2, nr=2

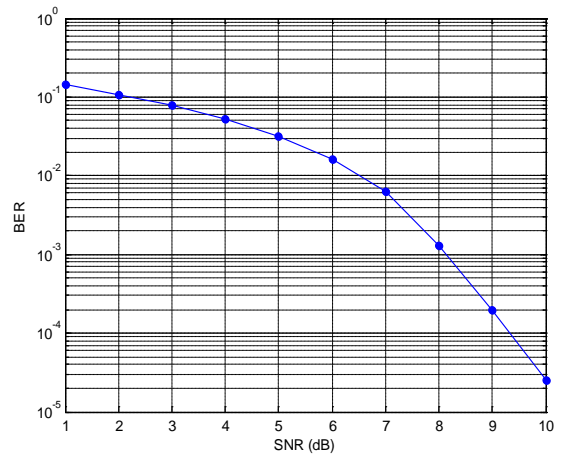

Fig.10: SIMO-OFDM in Ka band
 nt=4, nr=4

The performance study of Ka band signal shows that the attenuation of the rain and gases affect the transmission quality, for example in the case of SISO-OFDM, BER reaches a value of approximately 10^{-1.5} for an SNR equal to 11dB.

- The transition to two reception antennas (SIMO-OFDM) allows for minimizing BER reaching the value 10⁻³ for an SNR equal to 11dB.
- The use of MIMO-OFDM technology allows a significant improvement in signal quality, Example: for two transmitting and receiving antennas respectively, BER is 10^{-3.5} for an SNR equal to 11dB and four transmitting and receiving antennas, it is 10^{-4.7}.

9. Conclusion

The Ka-band signal undergoes attenuations degrading air quality. To remedy this problem, we have proposed in this paper, MIMO-OFDM-VBLAST systems.

This compensation technique allowed us to see the improvement of signal quality in terms of bit error rate, by increasing the number of transmitting and receiving antennas, and using a number of subcarriers equal to 512 and an encoding type to ensure transmission. The use of turbo codes is another issue for future investigation.

Reference

- [1] H.O. Anh Tai, "Application techniques of multicarrier OFDM Systems for future satellite", University of Toulouse, 30 March 2009.
- [2] B.Rihawi, "Analysis and mitigation of power ratio radio systems communications multi-antennas", University of Rennes I, 20 March 2008.
- [3] S.M.Alamouti, "A simple diversity technique for wireless communications", IEEE Journal on Selected Areas in communications, 16(8):1451–1458, October 1998.
- [4] I.Ouachani, "Performance analysis of communication systems wireless operator Micro and Macro Diversity", university of Paris XI Rosary, Discipline: Automatic and Signal Processing, June 28, 2005.
- [5] P.W.Wolniansky, G.J. Foschini, G.D. Golden, and R.A. Valenzuela, "V-BLAST : An Architecture for Realizing Very High Data Rates Over the Rich-Scattering Wireless Channel", Bell Laboratories, Lucent Technologies, Crawford Hill Laboratory 791 Holmdel-Keyport RD., Holmdel, NJ07733.
- [6] P. GRUYER and S. Paillard, "Modeling OFDM modulator and demodulator", University of Bretagne 12 December 2005.
- [7] R. Chaggara, "The continuous phase modulation for the Design of a Waveform Adaptive Application to Future Multimedia Systems Ka-band satellite", National School of Telecommunication.
- [8] N. Tao, "Study of Performance and Optimization of a Network Access Satellite Communications», 10 July 2009.